

DELTA GASKETS

Because of their geometric shape, delta gaskets require a higher level of precision from the seal grooves. As a direct result of the manufacturing process and its resulting precision, delta gaskets are only used for high-pressure autoclaves and high-pressure connections up to a maximum of 2000 mm, whereby the majority are less than 1000 mm. The following illustration shows the application as a cover gasket.

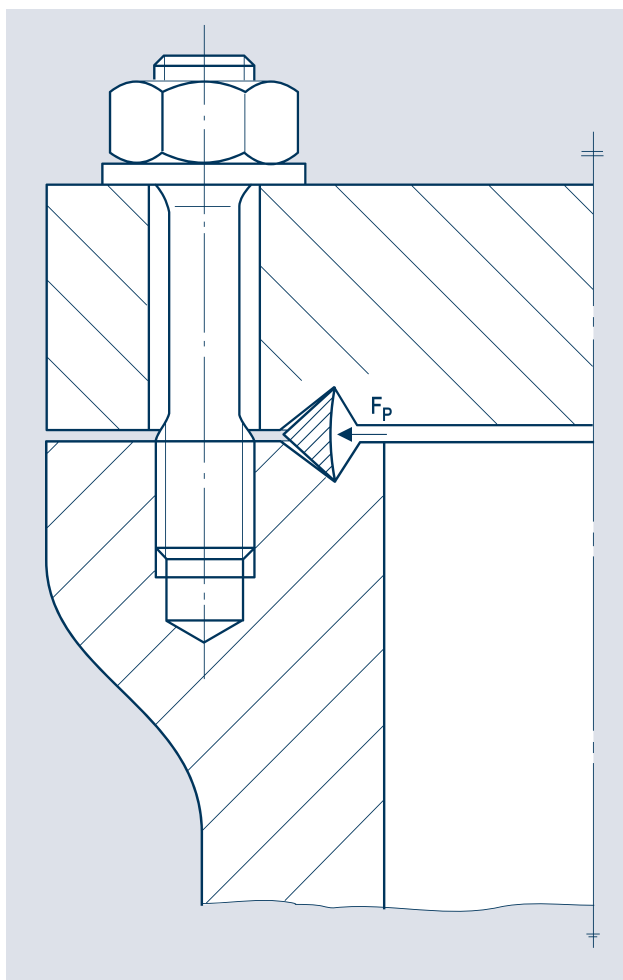

Due to its splined profile, an excellent initial seal is created by the partial plastic deformation of the opposing peaks of the gasket when bolt pre-tensioning force is applied. The radially self-sealing effect arises due to the high internal pressure resulting from the elastic extension of the gasket.

Delta gaskets are not suitable for dealing with intermittent pressures. Additional sealing layers are not practical or necessary. Delta gaskets are generally produced from seamless rings. The sealing material should be softer than the flange material if at all possible. Care should be taken to ensure adequate creep strength in the material. The gasket

is only slightly higher than the sum of the seal groove depths, therefore if the grooves are reworked at any stage a new gasket with greater height will be required.

We produce delta gaskets according to your documentation, from all usual materials. See also the section "Materials commonly used".

Gasket profiles

Profile	cross-section	Material	k_0 [mm]	k_1 [mm]	R_z^* [μ m]
A15		Steel	–		1,6 to 3,2

* Recommended maximum roughness of the flange surfaces.