

# DOUBLE SEALING SYSTEM

KHS/KNS with intermediate exhausting

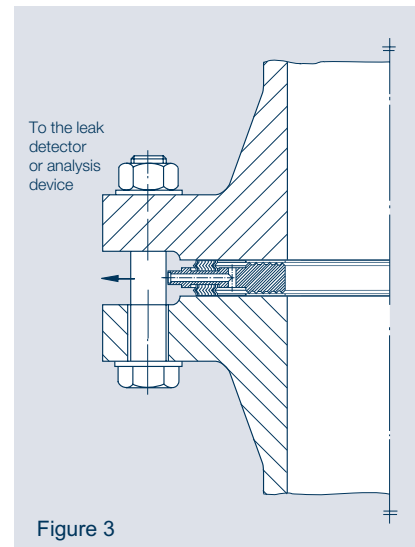
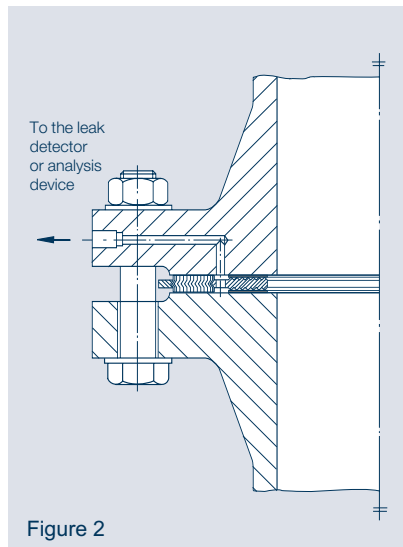
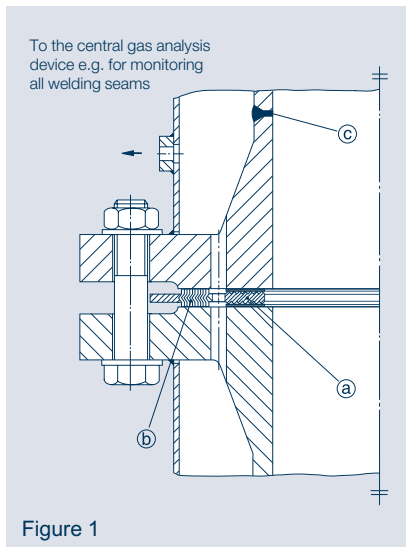

Old and new plants constantly place greater demands on safety and reliability. This applies at certain sizes to bolted flange connections on apparatuses, valves and pipelines. For many years, sealing systems with intermediate exhausting or certain areas of the chemical industry. The simplest example of this consists of two O-rings concentrically arranged in grooves.

This or similar designs are problem-free, as long as the components to be sealed are inherently stable and retain their position relative to each other. The bolt load applied, the internal pressure, the temperature or even external forces and moments all cause the flanges to take on a certain angle to each other, and so large deformations in the area of the seal should be anticipated.

The use of some gaskets leads to noticeable difficulties if the gasket is not able to securely seal the flanges as they slant against each other. The problem is even more difficult when two concentrically aligned gaskets are used.

If both gaskets are aligned as a main load seal or else if both are in off load contact, in each case significantly greater sealing recovery proportionate to the lever arms is required from a gasket than from other gaskets.

In many cases it has proven preferable not to have the components so inherently stable, so that leaks can be avoided with the pressure applied or with large applications of force

Only the combination of a main load gasket with a off load gasket as in the Kempchen double sealing system provides a secure design solution to this problem. Due to this special design, the double sealing system has proven a reliable sealing system in double-walled equipment or tanks as well as in double-lined pipes and flanges with intermediate exhausting. In double-walled systems with double sealing system gaskets the space between both walls can be used as extra heating or cooling or for monitoring any leakage arising, as shown in figure 1.

By exhausting or rinsing e.g. with nitrogen the leak-tightness of the internal gasket (a) and external gasket (b) and the welding seam (c) can always be monitored. In practice, in a 2" double sealing gasket a leak rate on the inner gasket of less than  $10^{-5} \text{ mbar} \cdot \text{l} \cdot \text{s}^{-1}$  can be measured for gaskets with graphite, and a leak rate of less than  $10^{-8} \text{ mbar} \cdot \text{l} \cdot \text{s}^{-1}$  for gaskets with PTFE.



In single-wall systems the internal and external gaskets can be monitored by intermediate exhausting in the flange. The principle of intermediate exhausting is shown in figure 2.

By changing the height of the gasket the intermediate exhausting can be done from the centring ring, see figure 3.

# DOUBLE SEALING SYSTEM

KHS/KNS with intermediate exhausting

## Gasket profiles

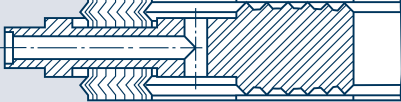
Profile	Cross-section
HN21A	
HN21H	
HN22A	
HN222A	

For main load gaskets, a gasket with greater spring stiffness such as a grooved gasket is used, whereas for off load gaskets a gasket with lower spring stiffness, such as a spiral wound gasket, is more appropriate. The height of the main load gasket is measured in such a way that the anticipated flange inclination and anticipated change in the flange inclination does not overload the off load gasket and allows it to be used safely.

Ask us for advice on the calculations and characteristic values of this gasket system.

The preferred areas of application for this gasket are:

- » Plants and pipelines in the chemical industry with carcinogenic, toxic or water-polluting intermediate and end products.
- » Tanks with pressurised liquid gases in large-capacity storage tanks e.g. ammonia
- » Equipment or pipelines with accompanying heating/cooling
- » Nuclear installations

Double sealing gaskets are supplied as a complete set, i.e. the spiral gasket is mounted on the outer ring of the inner gasket. The inner gasket is coated with a layer of PTFE, graphite or silver, depending on the operating conditions. It can also be supplied with an internally sealed PTFE envelope. The filler strip for the outer gasket can be either PTFE or graphite, depending on the operating conditions.

The standard material for the metal carrier of the inner gasket and for the metal strip of the spiral gasket is 1.4541 or 1.4571 steel. Other materials available on request. See also the section "Materials commonly used".

Double sealing systems can be used with smooth flanges, flanges with raised face and even with flanges with male and female faces, if the recess is wide and deep enough.

Double sealing system gaskets can only be reused on a limited basis, i.e. if the layers and/or the PTFE envelope and the spiral part are replaced, the gaskets can be used again, as long as there is no damage to the metal core of the primary gasket. Reprocessing is only economical for gaskets greater than DN 500 and is done in our workshop.

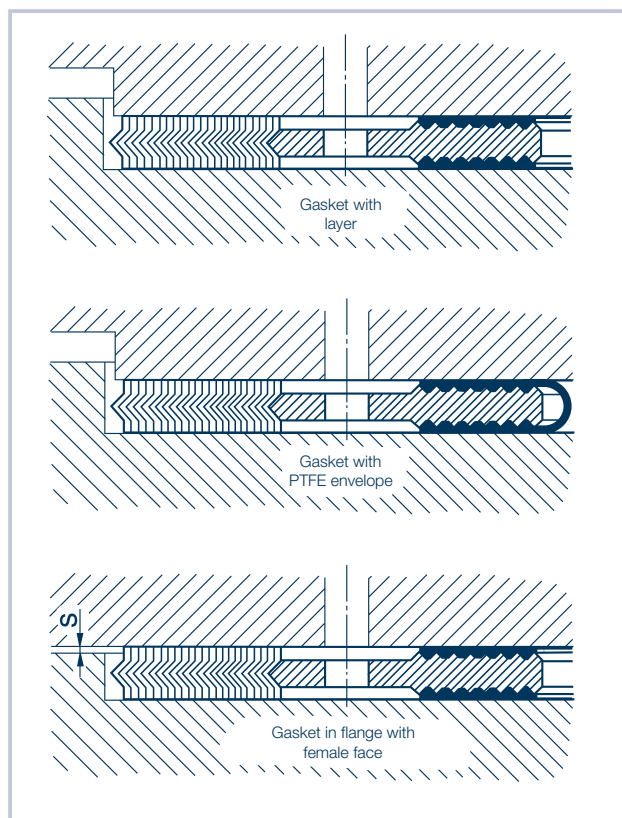

# DOUBLE SEALING SYSTEM

KHS/KNS with intermediate exhausting

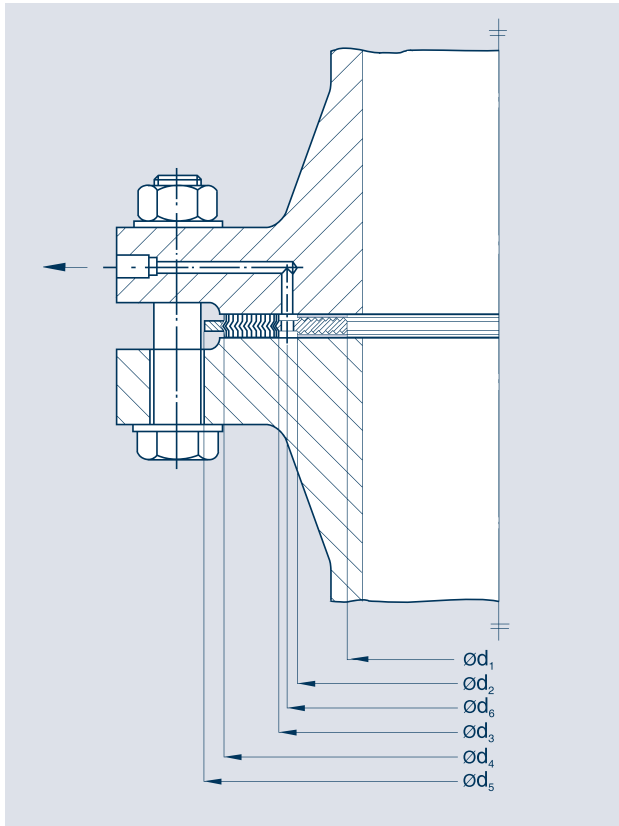

## Works standard 160

Ordering example for a double sealing gasket with layers, Profile HN22A, DN 100, PN 63, works standard 160, made of ...<sup>1)</sup>:

**Double sealing gasket, HN22A, DN 100, PN 63, works standard 160, 1.4541 / graphite**

08

## For DIN flanges PN 25 to PN 400

DN	d <sub>1</sub>	d <sub>2</sub>	d <sub>3</sub>	d <sub>4</sub>	PN		d <sub>5</sub>						intermediate exhausting
					25	40	63	100	160	250	320	400	d <sub>6</sub>
25	30	47	53	63	71	71	82	82	82	83	92	104	50
32	40	57	63	73	82	82	-	-	-	-	-	-	60
40	46	64	72	82	92	92	103	103	103	109	119	135	68
50	60	78	86	96	107	107	113	119	119	124	134	150	82
65	75	95	105	115	127	127	137	143	143	153	170	192	100
80	90	110	120	132	142	142	148	154	154	170	190	207	115
100	110	130	140	152	168	168	174	180	180	202	229	256	135
125	138	160	170	182	194	194	210	217	217	242	274	301	165
150	162	184	196	208	224	224	247	257	257	284	311	348	190
175	187	209	221	233	254	265	277	287	284	316	358	402	215
200	212	234	246	260	284	290	309	324	324	358	398	442	240
250	262	284	296	310	340	352	364	391	388	442	488	-	290
300	312	334	346	360	400	417	424	458	458	536	-	-	340
350	348	372	388	404	457	474	486	512	-	-	-	-	380
400	396	422	438	454	514	546	543	572	-	-	-	-	430
450	444	472	488	504	-	571	-	-	-	-	-	-	480
500	494	522	538	558	624	628	657	704	-	-	-	-	530
600	600	632	648	668	731	747	764	813	-	-	-	-	640

- Flanges compliant with the standard not available

Dimensions in mm

<sup>1)</sup> Specify material when placing order

# DOUBLE SEALING SYSTEM

KHS/KNS with intermediate exhausting

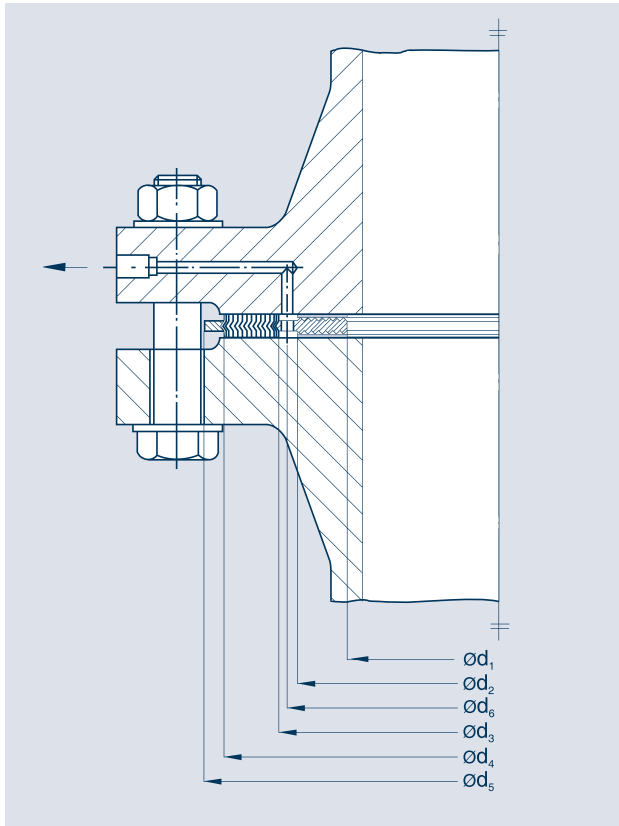

## Works standard 161

Ordering example for a double sealing gasket with layers, Profile HN22A, NPS 5, Class 600, works standard 161, made of ...<sup>1)</sup>:

**Double sealing gasket, HN22A, 5", Class 600, works standard 161,1.4541 / graphite**

08

## For ANSI flanges Class 150 to Class 2500

DN	d <sub>1</sub>	d <sub>2</sub>	d <sub>3</sub>	d <sub>4</sub>	PN		d <sub>5</sub>					intermediate exhausting
					150 lbs	300 lbs	400 lbs	600 lbs	900 lbs	1500 lbs	2500 lbs	d <sub>6</sub>
1½	42	56	62	72	82,5	92,1	92,1	92,1	95,2	95,2	114,3	59
2	55	73	79	90	101,6	108,0	108,0	108,0	139,7	139,7	142,8	76
2½	65	83	91	102	120,6	127,0	127,0	127,0	161,9	161,9	165,1	87
3	81	99	111	124	133,4	146,1	146,1	146,1	165,1	171,5	193,7	105
3½	93	111	123	136	158,8	161,9	158,7	158,7	-	-	-	117
4	105	128	139	152	171,5	177,8	174,6	190,5	203,2	206,4	231,7	133
5	131	156	166	178	193,7	212,7	209,5	238,1	244,5	250,8	276,2	161
6	155	183	193	206	219,1	247,7	244,5	263,5	285,8	279,4	314,3	188
8	206	236	247	260	276,2	304,8	301,6	317,5	355,6	349,3	384,1	242
10	258	290	301	314	336,5	358,8	355,6	396,9	431,8	431,8	473,0	296
12	308	342	355	370	406,4	419,1	415,9	454,0	495,3	517,5	546,1	349
14	340	376	388	403	447,7	482,6	479,4	488,9	517,5	574,7	-	382
16	395	433	445	460	511,2	536,6	533,4	561,9	571,5	638,1	-	439
18	445	489	507	524	546,1	593,7	590,5	609,6	635,0	701,7	-	498
20	493	541	557	574	603,2	650,9	644,5	679,5	695,3	752,4	-	549
22	544	598	612	631	657,2	701,7	698,5	730,3	-	-	-	605
24	595	650	662	682	714,4	771,5	765,2	878,4	835,0	898,5	-	656

- Flanges compliant with the standard not available

Dimensions in mm

<sup>1)</sup> Specify material when placing order.