

RUBBER COMPENSATORS

Design 1 + 2

Design 1 with rotating flanges

Highly elastic pipe connectors

For all sectors of industry, apparatus and pipeline construction, power plants, shipbuilding, fuel pumps, heating, climate control and ventilation plants, etc.

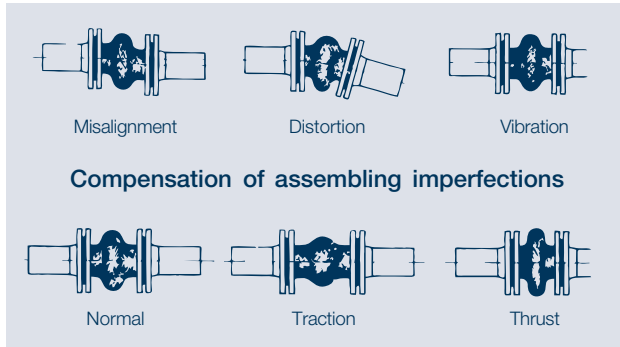

Use

Absorption of axial and radial expansion, noise, vibrations and oscillations. For subsidence of buildings and containers, assembling imperfections, for electrical insulation, for nearly total noise absorption in pipelines, domestic supply mains, heating systems, pump and motor connections.

Construction

Smooth inside and out, high pressure-resistant textile fabric interlinings with moulded rubber stub end vulcanised on both sides, with embedded steel wire reinforcement that allows for accurate and complete adaption to the counterflange. Therefore no gaskets are necessary.

Flanges

Rotating, made from carbon steel, galvanised, zinc-plated and chromatised; or high-grade steel, plastic, etc., bored in accordance with DIN, also available in special designs in accordance with ASA, BS, etc.

Installation instructions

Low inherent resistance allows a very simple installation (no additional tools necessary). The pipelines are to be secured by a sufficient number of anchors (fixed points).

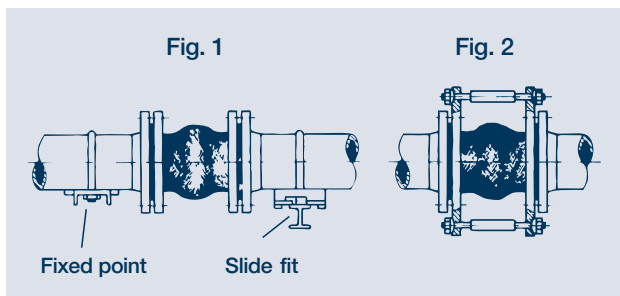

(Fig. 1) For axial expansion, our movement limiters (Fig. 2) serve a stroke-limiting function.

For lateral expansion absorption and for noise absorption, the movement limiters serve to relieve the load on the anchors.

Use

For noise absorption, rubber compensators with movement limiters (Fig. 2) and a shorter overall length are generally recommended for installation.

A shorter installation is also recommended for expansion absorption at a traction and thrust of +/- 20 mm. The installation for other operating behaviours is based on the expansion absorption. However, under no circumstances should the overall length exceed 130 mm. In the event of low pressure and high suction operation, use a high-grade steel inner support ring.

Available in various rubber qualities

Type	Surface (inner)	Surface (outer)
red	EPDM* for warm water, wastewater (including those with added acids and bases), water and drinking water (not suitable for media containing oil).	EPDM*
yellow	Perbunan* for petroleum products, premium fuel and cooling water with corrosion protection oils up to 90 °C	Neoprene*
green	Hypalon* specially designed for acids and bases (chemicals) Pressure and temperature depending on the abrasiveness of the medium, up to 80 °C	Hypalon*
	Special design with ultra heat-resistant textile interlinings EPDM* for heating water, cooling water, hot air up to 110 °C (up to 6 bar); temporarily up to 130 °C Not suitable for drinking water or media containing oil	EPDM*

* Materialcode designation see "Material commonly used".

Special advantages:

Low inherent resistance, short installation length, excellent axial and radial expansion absorption and noise reduction.

When making an enquiry or placing an order, please indicate:

Expansion absorption +/- mm
 Medium, operating pressure bar
 Operating temperature °C

RUBBER COMPENSATORS

Design 1 + 2

Design 1 with rotating flanges

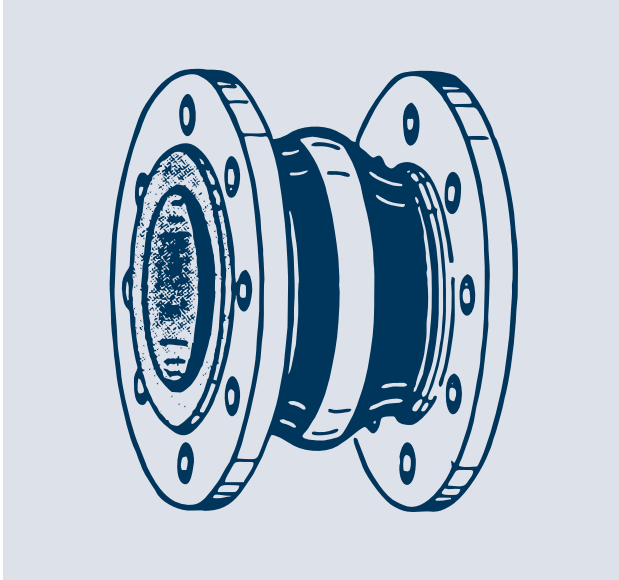

Standard design with loose rotating flanges on both sides

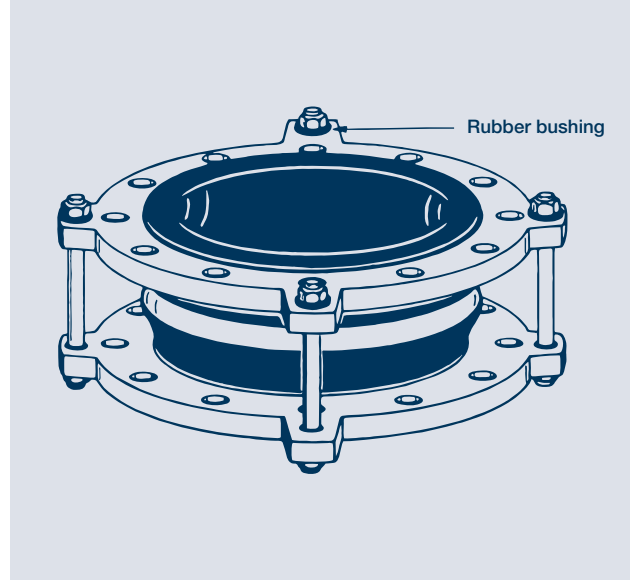

Standard design with noise-absorbing movement limiters

Dimensions for Type 1 with standard steel flanges

Allowable loads for types yellow, green, red

Nominal Flange mating dimensions according to DIN 2501									Pressure		Max. vacuum where L= Normal		Total length**			movement	
DN		Nominal-pressure PN	D mm	k mm	g mm	l mm	b mm	W mm	operating bar	test Cold water bar	without m WS	with m WS	L Normal mm	L Thrust mm	L Traction mm	lateral ± mm	angular ± °
I.D. mm	I.D. in.																
25	1"	10/16	115	85	66	4x14	18	81	16	25	7		130	100	160	30	35
32	1¼"	10/16	140	100	66	4x18	18	81	16	25	7		130	100	160	30	35
40	1½"	10/16	150	110	70	4x18	19	86	16	25	6		130	100	160	30	35
50	2"	10/16	165	125	90	4x18	19	96	16	25	6		130	100	160	30	35
65	2½"	10/16	185	145	105	4x18	19	111	16	25	6	10	130	100	160	30	30
80	3"	10/16	200	160	116	8x18	21	122	16	25	5	10	130	100	160	30	30
100	4"	10/16	220	180	138	8x18	21	142	16	25	5	9	130	100	160	30	25
125	5"	10/16	250	210	165	8x18	21	168	16	25	3	8	130	100	160	30	25
150	6"	10/16	285	240	190	8x23	21	192	16	25	3	8	130	100	160	30	20
200	8"	10	340	295	250	8x23	26	252	16*	25	2	8	130	100	160	30	15
250	10"	10	395	350	300	12x23	26	302	16*	25	2	8	130	100	160	30	10
300	12"	10	445	400	350	12x23	26	354	16*	25	2	8	130	100	160	30	10
400	16"	10	565	515	455	16x26	26	480	10	16	2	8	200	150	230	30	8
500	20"	10	670	620	555	20x26	28	580	10	16	2	8	200	150	230	30	6
600	24"	10	780	725	670	20x30	28	680	10	16	2	8	200	150	230	30	6

*) only for flanges PN 16

**) Special installation length on request

Materials, dimensions and/or application conditions subject to change at any time.

RUBBER COMPENSATORS

Design 1 + 2

Design 2

KLINGER Kempchen rubber fabric compensators with an extremely robust design for use in pipeline construction, ship-building, aggregate and power plant construction. Due to the flow-favourable bulge, they may be used both horizontally and vertically.

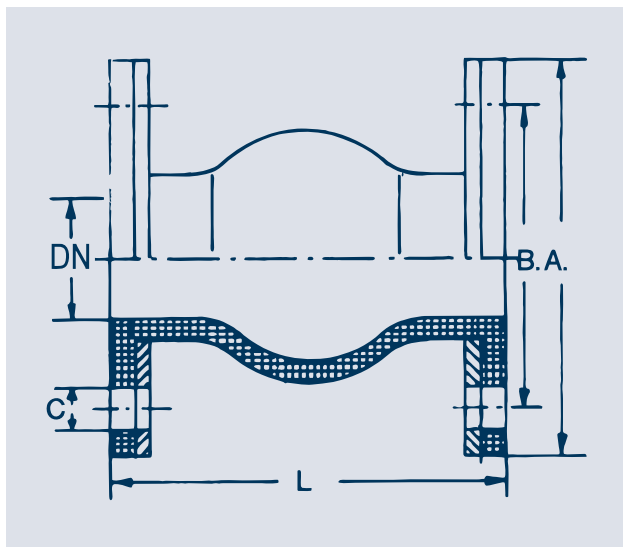

In EPDM quality, these parts are especially hot-water resistant and suitable for installation in hot water plants.

Rubber inside: Suitable for carrying freshwater, cooling water, ocean water and hot water up to 120 °C.

Interlining: Synthetic fibre, highly tear-proof and rot-resistant

Rubber outside: Non-aging, oil and weather-proof, and particularly flame-resistant

Flanges: Backing flange and collar rings made from carbon steel

Compensators are available upon request in NBR, chloroprene, EPDM (APTK), hypalon and drinking water design, with expansion limiters and teflon lining. Vacuum support rings can be inserted/incorporated; however, due to the construction of the compensators, these are not necessary in most cases.

KLINGER Kempchen rubber fabric compensators in design 2 are characterised by their reliability and durability.

DN I.	Overall length L	Nominal pressure	Flange according to DIN 2632 PN 10		
			Outer-Ø (A)	Circle-Ø (B)	Number of holes x Ø (C)
175	180	6	315	270	8 x 23
200	180	6	340	295	8 x 23
225	180	4	370	325	8 x 23
250	180	4	395	350	12 x 23
300	185	4	445	400	12 x 23
350	225	4	505	460	16 x 23
400	225	4	565	515	16 x 27
450	250	4	615	565	20 x 27
500	250	4	670	620	20 x 27
600	250	3,5	780	725	20 x 30
700	250	3,5	895	840	24 x 30
800	250	3,5	1015	950	24 x 33
900	250	3	1115	1050	28 x 33
1000	250	3	1230	1160	28 x 36
1200	250	3	1455	1380	32 x 39
1300	250	3	1575	1490	32 x 42
1400	250	3	1675	1590	36 x 42
1500	250	3	1785	1700	36 x 42
1600	250	3	1915	1820	40 x 48

Materials, dimensions and/or application conditions subject to change at any time.

RUBBER COMPENSATORS

Design 1 + 2

Higher pressure ranges and flange designs in accordance with DIN for PN 6, PN 16 are available upon request. Different flange finishes, for instance zinc-plating, are also available.

Greater nominal diameter and differing installation lengths are available upon request

The availability of large quantities of moulding material enables us to provide for special requests regarding installation length and special designs during manufacture. Please make any special requests when indicating flange dimensions, pressure range, temperature, expansion absorption, vacuum and installation length.

Kempchen rubber fabric compensators counteract axial expansion and radial displacement that may arise from fluctuations in temperature and shocks. Damages caused by improper installation can be avoided by observing the following installation instructions.

Following these instructions is essential for the proper function and long duration of your compensator.

Assembling instructions

1. Screw bolts may be placed on both sides. The head of the screw should point to the bellows of the compensator.
2. Tighten screws above the corner, keep the key inside, turn outside to avoid damaging the rubber bellows with the tools.
3. Tighten the screws only moderately, as the rubber step creates a good seal and excessively tight screws will crush the rubber step.
4. Make sure that the pipeline flange corresponds to the nominal diameter in the inner \varnothing (DN of the compensator = inner \varnothing); otherwise, please contact us.

Installation instructions

1. Install rubber compensators in such a way as to allow inspection
2. If possible, load rubber compensators in thrust mode. Greater elongation in operation condition requires pre-loading. Torsion is not permissible.
3. The distance from the anchor or pipe ducts may not exceed $3 \times \text{DN}$. Only 1 compensator between 2 fixed points.
4. In the absence of a sufficient number of anchors, use the compensator design with a length-limiter to absorb reaction force. Length-limiters are always set at overall length.
5. Do not coat rubber compensators with paint.
6. Do not exceed the maximum allowable temperature stress (including external radiation heat).

Fig. 1

